



USB Blaster USB Port Download Cable

March 2003, Version 1.0

Data Sheet

Features

- Allows PC users to perform the following functions:
 - Program MAX[®] 9000, MAX 7000S, MAX 7000AE, MAX 7000B, MAX 3000A, EPC2, enhanced configuration (EPC4, EPC8, and EPC16) and serial (EPCS) configuration devices in-system.
 - Configure Stratix[™], Stratix[™] GX, Cyclone[™], APEX[™] II, APEX 20K (including APEX 20K, APEX 20KE, and APEX 20KC), ACEX[®] 1K, Mercury[™], FLEX[®] 10K (including FLEX 10KA and FLEX 10KE), FLEX 8000, FLEX 6000, and Excalibur[™] devices.
- Supports target systems using 5.0 V TTL, 3.3 V LVTTTL/LVCMOS, and single-ended I/O standards from 3.3 V down to 1.5 V.
- Provides a fast and low-cost method for in-system programming
- Supported by the Altera[®] Quartus[®] II development software
- Interfaces with a standard USB port on PCs
- Uses a 10-pin circuit board connector, which is compatible with the ByteBlaster[™] II, ByteBlasterMV[™] parallel port cable, and BitBlaster[™] serial download cable
- Supports SignalTap[®] II logic analysis in the Quartus II software

Functional Description

The USB Blaster USB port download cable interfaces to a standard USB PC port (ordering code: PL-USB-BLASTER). This cable drives configuration data from the PC to Stratix, Stratix GX, Cyclone, APEX II, APEX 20K (including APEX 20K, APEX 20KE, and APEX 20KC), ACEX 1K, Mercury, Excalibur, FLEX 10K (including FLEX 10KA and FLEX 10KE), FLEX 8000, and FLEX 6000 devices, as well as programming data to MAX 9000, MAX 7000S, MAX 7000AE, MAX 7000B, MAX 3000A devices and EPC/EPCS configuration devices. Because design changes are downloaded directly to the device, prototyping is easy and multiple design iterations can be accomplished in quick succession.

Download Modes

The USB Blaster cable provides three download modes:

- Active Serial (AS) mode—Used for programming serial (EPCS) configuration devices.
- Passive serial (PS) mode—Used for configuring Stratix, Stratix GX, Cyclone, APEX II, APEX 20K, Mercury, ACEX 1K, Excalibur, FLEX 10K, FLEX 8000, and FLEX 6000 devices
- JTAG mode—Industry-standard Joint Test Action Group (JTAG) interface for programming or configuring Stratix, Stratix GX, Cyclone, APEX II, APEX 20K, Mercury, ACEX 1K, Excalibur,

FLEX 10K, MAX 9000, MAX 7000S, MAX 7000AE, MAX 7000B, and MAX 3000A devices, and EPC configuration devices.

USB Blaster Connections

The USB Blaster cable has a USB universal plug that connects to the PC USB port, and a 10-pin female plug that connects to the circuit board. Data is downloaded from the PC's USB port through the USB Blaster cable to the circuit board via the connections discussed in this section.

 The USB Blaster $V_{CC(TRGT)}$ pin must be connected to a specific voltage for the device being programmed (Table 1). Connect pull-up resistors to the same power supply as the USB Blaster $V_{CC(TRGT)}$.

Family	USB Blaster VCC Voltage Required
MAX 7000S	5 V
MAX 7000AE, MAX 3000A	3.3 V
MAX 7000B	2.5 V
Stratix, Stratix GX	As specified by V_{CCSEL}
Cyclone, APEX II, APEX 20K, Mercury	As specified by V_{CCIO}
FLEX 10K, FLEX 8000, FLEX 6000	5 V
FLEX 10KE	2.5 V
FLEX 10KA, FLEX 6000A	3.3 V
EPC2	5 V or 3.3 V
EPC4, EPC8, EPC16	3.3 V
EPCS1, EPCS4	3.3 V

USB Blaster Header & Plug Connections

A standard B-connector connects to a USB port with a standard USB cable.

The 10-pin female plug connects to a 10-pin male header on the circuit board containing the target device(s). Figure 1 shows the dimensions of the female plug.

Figure 1. USB Blaster 10-Pin Female Plug Dimensions

Dimensions are shown in inches. The spacing between pin centers is 0.1 inch.

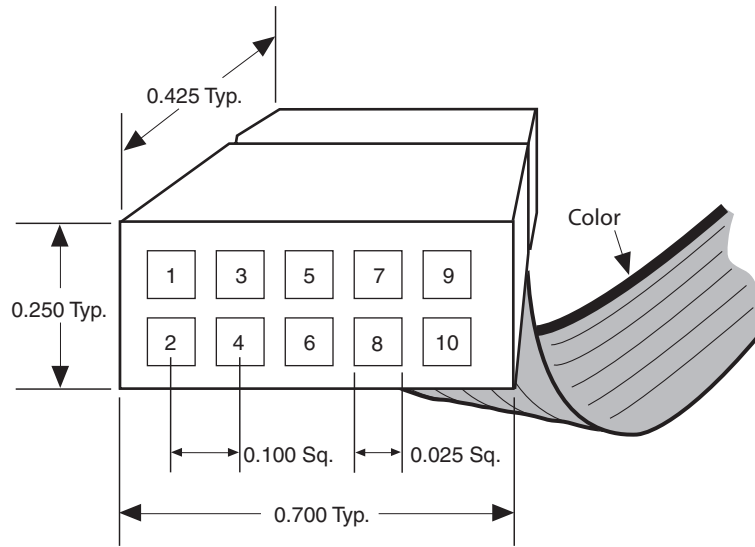



Table 2 identifies the 10-pin female plug's pin names for the corresponding download mode.

Pin	AS Mode		PS Mode		JTAG Mode	
	Signal Name	Description	Signal Name	Description	Signal Name	Description
1	DCLK	Clock Signal	DCLK	Clock signal	TCK	Clock signal
2	GND	Signal Ground	GND	Signal ground	GND	Signal ground
3	CONF_DONE	Configuration Done	CONF_DONE	Configuration Done	TDO	Data from device
4	V _{CC(TRGT)}	Target Power Supply	V _{CC(TRGT)}	Target Power Supply	V _{CC(TRGT)}	Target Power Supply
5	nCONFIG	Configuration Control	nCONFIG	Configuration control	TMS	JTAG state machine control
6	nCE	Cyclone Chip Enable	–	No connect	–	No connect
7	DATAOUT	Active Serial Data Out	nSTATUS	Configuration status	–	No connect
8	nCS	Serial Configuration Device Chip Select	–	No connect	–	No connect
9	ASDI	Active Serial Data In	DATA0	Data to device	TDI	Data to device
10	GND	Signal Ground	GND	Signal ground	GND	Signal ground

 The circuit board must supply V_{CC(TRGT)} and ground to the USB Blaster cable for the I/O drivers.

Circuit Board Header Connection

The USB Blaster 10-pin female plug connects to a 10-pin male header on the circuit board. The 10-pin male header has two rows of five pins, which are connected to the device's programming or configuration pins. The USB Blaster cable receives power for the I/O drivers and downloads data via the male header. Figure 2 shows the dimensions of a typical 10-pin male header.

Figure 2. 10-Pin Male Header Dimensions

Dimensions are shown in inches.

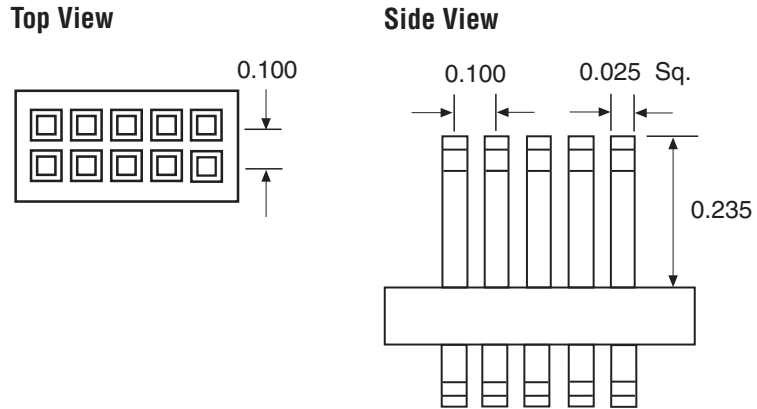

Operating Conditions

Tables 3 through 5 summarize the absolute maximum ratings, recommended operating conditions, and DC operating conditions for the USB Blaster cable.

Table 3. USB Blaster Cable Absolute Maximum Ratings

Symbol	Parameter	Conditions	Min	Max	Unit
$V_{CC(TRGT)}$	Target Supply voltage	With respect to ground.	-0.3	5.5	V
$V_{CC(USB)}$	USB Supply Voltage	With respect to ground.	-0.5	6.0	V
I_I	Input current	TDO or Dataout	-10.0	10.0	mA
I_O	Output current	TCK, TMS, TDI, nCS, nCE	-20.0	20.0	mA

Table 4. USB Blaster Cable Recommended Operating Conditions

Symbol	Parameter	Conditions	Min	Max	Unit
$V_{CC(TRGT)}$	Target Supply voltage, 5.0-V operation		4.75	5.25	V
	Target Supply voltage, 3.3-V operation		3.0	3.6	V
	Target Supply voltage, 2.5-V operation		2.375	2.625	V
	Target Supply voltage, 1.8-V operation		1.71	1.89	V
	Target Supply voltage, 1.5-V operation		1.43	1.57	V

Table 5. USB Blaster Cable DC Operating Conditions

Symbol	Parameter	Conditions	Min	Max	Unit
V _{IH}	High-level input voltage		V _{CC(TRGT)} -0.2		V
V _{IL}	Low-level input voltage			0.15	V
V _{OH}	5.0-V high-level output voltage	V _{CC(TRGT)} = 4.5 V, I _{OH} = 8 mA	4.4		V
	3.3-V high-level output voltage	V _{CC(TRGT)} = 3.0 V, I _{OH} = 4 mA	2.9		V
	2.5-V high-level output voltage	V _{CC(TRGT)} = 2.375 V, I _{OH} = 2 mA	2.275		V
	1.8-V high-level output voltage	V _{CC(TRGT)} = 1.71 V, I _{OH} = 2 mA	1.61		V
	1.5-V high-level output voltage	V _{CC(TRGT)} = 1.43 V, I _{OH} = 2mA	1.33		V
V _{OL}	5.0-V low-level output voltage	V _{CC(TRGT)} = 5.5 V, I _{OL} = 8 mA		0.125	V
	3.3-V low-level output voltage	V _{CC(TRGT)} = 3.6 V, I _{OL} = 4 mA		0.125	V
	2.5-V low-level output voltage	V _{CC(TRGT)} = 2.625 V, I _{OL} = 2 mA		0.125	V
	1.8-V low-level output voltage	V _{CC(TRGT)} = 1.89 V, I _{OL} = 2 mA		0.125	V
	1.5-V low-level output voltage	V _{CC(TRGT)} = 1.57 V, I _{OL} = 2mA		0.125	V
I _{CC(USB)}	Operating current (No Load)	(Typical I _{CC(USB)} = 80mA)		150	mA

Software Instructions

Altera’s Quartus II design software package provides the programmer function required to configure or program devices using the USB Blaster download cable.

Quartus II Instructions

To configure or program one or more devices with the USB Blaster cable and the Quartus II Programmer perform the following steps.



For a detailed explanation of the programming process, see the Tutorial section of the Quartus II Help system.

1. Compile a project. The Quartus II compiler generates either an SRAM object file (.sof) file, a Programmer Object File (.pof) or a JAM STAPL format file depending on the target device.
2. Attach the USB Blaster cable to a USB port on the PC running the Quartus II software and insert the 10-pin female plug into the prototype system containing the target device. The board must supply power for the I/O drivers. Power for the cable is provided from the USB bus to the USB Blaster cable.



A driver must be installed before using the USB Blaster cable with the Windows 2000 and Windows XP operating systems. For instructions on installing USB Blaster drivers, go to the “USB Blaster and MasterBlaster Installation” section in the *Quartus II Installation and Licensing for PCs Manual*.

3. Open the Quartus II programmer by selecting **Programmer** from the (Tools menu). Choose **Setup** in the Programming Hardware section. Please see "Changing Setup" under the USB Blaster cable in the Quartus II software Help menu for more information.
4. Select either active serial, passive serial, or JTAG programming mode and then add the files and/or devices you want to program or configure using the **add file** or **add device** buttons to create a chain description file (.cdf).

The programmer has three programming modes: active serial, passive serial, and JTAG. In active serial mode, a single EPCS POF is selected, and you can choose from several programming options. In passive serial mode, you select which SOFs to include in the device chain. In JTAG mode, you add specific devices and configuration devices to the device chain, in addition to POFs and SOFs, and you have several programming options for each configuration device in the chain.

In JTAG mode, you can verify MAX device and EPC configuration device contents against its programming file data, check that a device is blank, examine a programmed device and save its data to file, or use its data to program or verify another configuration device. You can perform these functions for EPCS configuration devices using active serial mode.

5. Click **start** in the Quartus II Programmer to program or configure the device(s). The USB Blaster cable downloads the data from the SOF and/or POF file(s) into the device(s).



For further information, refer to the tutorial section of the Quartus II Help.

Conclusion

Downloading configuration and programming data directly to the device via the USB Blaster cable allows designers to verify multiple design iterations in quick succession, thereby speeding the design cycle.

References

For more information on configuration and in-system programmability (ISP), see the following sources:

- *AN 39: IEEE 1149.1 (JTAG) Boundary-Scan Testing in Altera Devices*
- *AN 95: In-System Programmability in MAX Devices*
- *AN 116: Configuring APEX 20K, FLEX 10K & FLEX 6000 Devices*
- *AN 208: Configuring Stratix & Stratix GX Devices*
- *AN 250: Configuring Cyclone FPGAs*
- *Serial Configuration Devices Data Sheet*
- Search for “USB Blaster,” “Programming a Single Device or Multiple Devices in JTAG or Passive Serial Chains with the MasterBlaster or USB Blaster,” “Configuration Scheme Description,” “Programmer Introduction,” and “Programming” in the Quartus II Help system.
- Data sheet: *Enhanced Configuration Devices (EPC4, EPC8 & EPC16)*



101 Innovation Drive
San Jose, CA 95134
(408) 544-7000
<http://www.altera.com>
Applications Hotline:
(800) 800-EPLD
Literature Services:
lit_req@altera.com

Copyright © 2003 Altera Corporation. All rights reserved. Altera, The Programmable Solutions Company, the stylized Altera logo, specific device designations, and all other words and logos that are identified as trademarks and/or service marks are, unless noted otherwise, the trademarks and service marks of Altera Corporation in the U.S. and other countries. All other product or service names are the property of their respective holders. ARM is a registered trademark of ARM Limited. ModelSim and Mentor Graphics are registered trademarks and LeonardoSpectrum, Exemplar Logic, and Model Technology are trademarks of Mentor Graphics Corporation. Altera products are protected under numerous U.S. and foreign patents and pending applications, maskwork rights, and copyrights. Altera warrants performance of its semiconductor products to current specifications in accordance with Altera's standard warranty, but reserves the right to make changes to any products and services at any time without notice. Altera assumes no responsibility or liability arising out of the application or use of any information, product, or service described herein except as expressly agreed to in writing by Altera Corporation. Altera customers are advised to obtain the latest version of device specifications before relying on any published information and before placing orders for products or services.

